

Spacefaring Logistics Infrastructure Fact Sheet

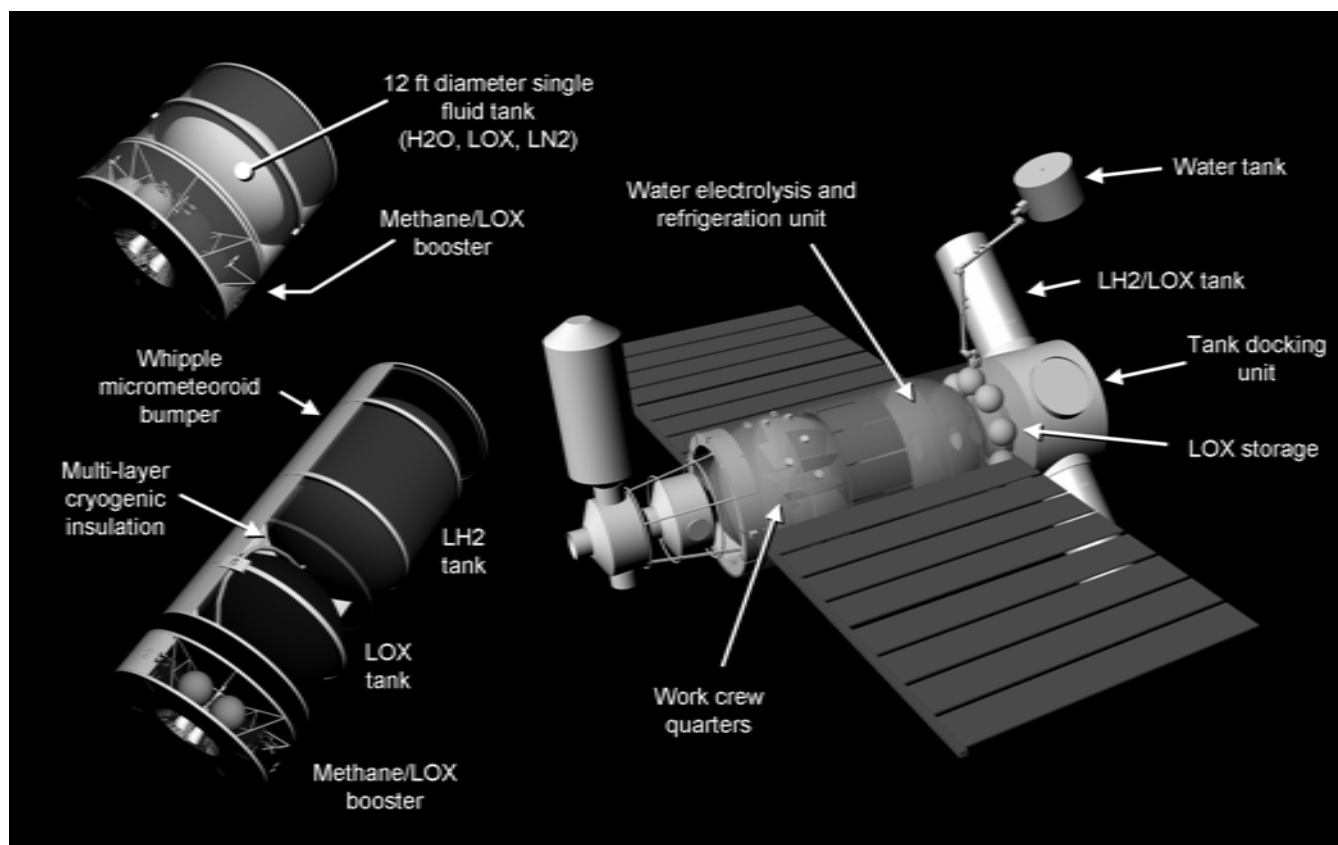

1. System name: **Space propellant station**
2. Infrastructure phase deployed: 2
3. Function: Stores and provides propellants for the space logistics depot
4. 2007 Technology Readiness Level: 6-9
5. Description:
 - To maximize chemical rocket engine performance, the in-space logistics infrastructure, with the exception of the space tug, uses hydrogen and oxygen propellants.
 - Each human-year in space requires about 10 tons of water. To minimize transportation requirements and to enhance transport safety, the space logistics depot uses a water "economy" where water is first used for human uses. Captured waste water is then recycled into propellants, O₂ for life support, and organic waste that is freeze-dried into radiation shielding packets.
 - The design of the space propellant station is based on the space construction station where the latter's work compartment is used to house the electrolysis units and the cryogenic refrigeration units.
 - This design approach enables the electrolysis compartment to be operated in a vacuum or

inert gas environment for safety and then to be pressurized with an inert gas for maintenance and repair. The maintenance crews enter the compartment wearing simple respirators.

- Electricity to power the space propellant station is provided by a separate co-orbiting solar electric array (not shown in the illustration). Approximately 90,000 ft² of 25% efficient solar arrays, producing approximately 2 MWe peak (initial estimate), is required to produce approximately 180 tons of cryogenic propellants per year—processing the water recycled from each space logistics base of 20 people.
- Each space habitat of 100 people will require 5 additional space propellant stations to process the waste water yielding approximately 900 tons of propellants each year.
- The six space propellant stations at each space logistics depot will handle approximately \$2.2B worth of propellants each year, based on Gen.1 aerospaceplane mission costs of \$25M for 12.5 tons of delivered propellants.